

TAIYO ^{LOW VOLTAGE} **F** BRUSHLESS

SUMMARY

A.C. SERIES GENERATOR

Applicable Output
10 kVA thru. 4000 kVA



TAIYO
ELECTRIC CO.LTD.

TAIYO F SERIES

BRUSHLESS A.C. GENERATOR

ensures you an easy working environment through its great reliability.

TAIYO "F" SERIES has been developed from the viewpoint of the user by utilizing our long years of extensive experience and wealthy performance as a specialized manufacturer of marine use electrical equipment so that it provides satisfactory operation in electrically and mechanically against the severe and special conditions of marine use machinery.

The COMPACT AND FUNCTIONAL DESIGN and WIDE RANGE OF APPLICATION of the respective models for all types of usage conditions, capacities, specifications etc., allow the user to have the model that is precisely suited to the needs.

We are confident that this series can adequately satisfy the needs of any user.

The high-quality "F" SERIES is the product of a SUPERB MANUFACTURING LINE that utilizes the MOST UP-TO-DATE TECHNOLOGY.

This series offers the THOROUGH QUALITY-CONTROL, that have been the pride of our company for many years, SEVERE MANAGEMENT OF DELIVERY, and the PROMPT AND COURTEOUS AFTER-SALES SERVICE. This and the REASONABLE PRICE have meant that this series is being well-used and praised by users around the world.

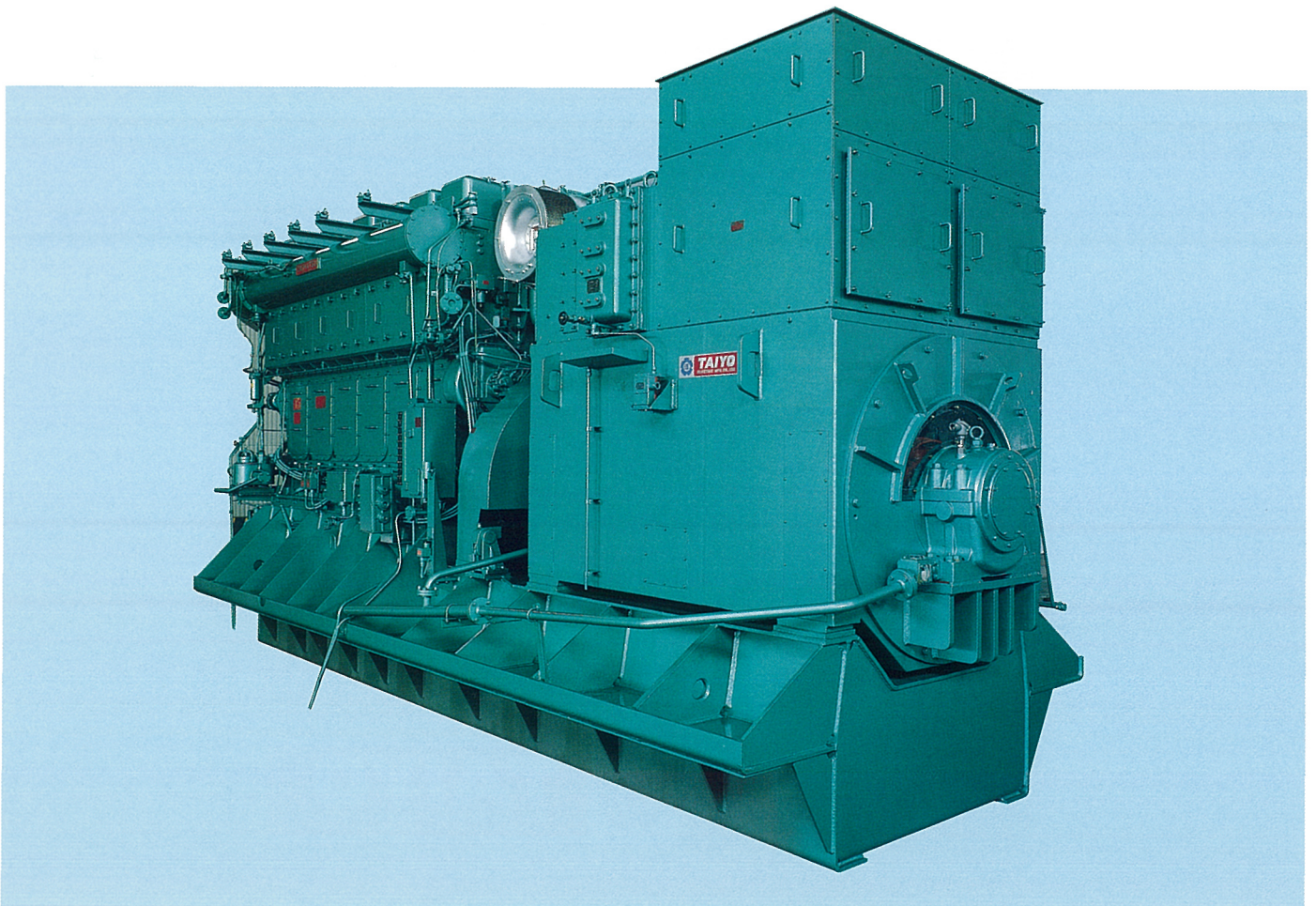

STANDARD SPECIFICATIONS

Output: 10 — 4,000 kVA
 Number of poles: 2P — 12P
 Voltage: 450V, 225V, 380V
 3.3kV, 6.6kV, 11kV or 13.8kV
 Frequency: 60 Hz or 50 Hz
 Number of phase: 3 phase 3 wire
 Power factor: $\cos\phi = 0.8$
 Rating: Continuous
 Ambient temperature: 45°C or 50°C

Insulation: F class
 Excitation: Brushless with A.V.R.
 Bearing: Ball or sleeve, End bracket or pedestal
 Lubrication: Grease or Self oil ring or Forced by separate L. O. system
 Enclosure: Enclosed drip-proof type (IP-22, 23) or Totally-enclosed type (IP-44)
 • Refer to the pamphlet of each model for the details.

APPLICABLE STANDARDS & RULES

TAIYO "F" SERIES MARINE BRUSHLESS AC GENERATORS comply with the specification of the following Classification Societies and Standards.

- Classification Societies:
 - NK Nippon Kaiji Kyokai
 - LR Lloyd's Register of Shipping
 - ABS American Bureau of Shipping
 - DNV Det Norske Veritas
 - BV Bureau Veritas
 - GL Germanischer Lloyd
 - CCS China Classification Society
 - KR Korean Register of Shipping
 - KI P.T. (Persero) Klasifikasi Indonesia
 - CR China Corporation Register of Shipping
 - Standards:
 - ISO International Organization for Standardization
 - IEC International Electrotechnical Commission
 - JIS Japanese Industrial Standards
 - JEC Standard of the Japanese Electrical Committee
 - JEM The standard of the Japan Electrical Manufacturers' Association
- Other Classification Societies and Standards not listed above may also be complied by the consultation.

MODEL APPLICATION

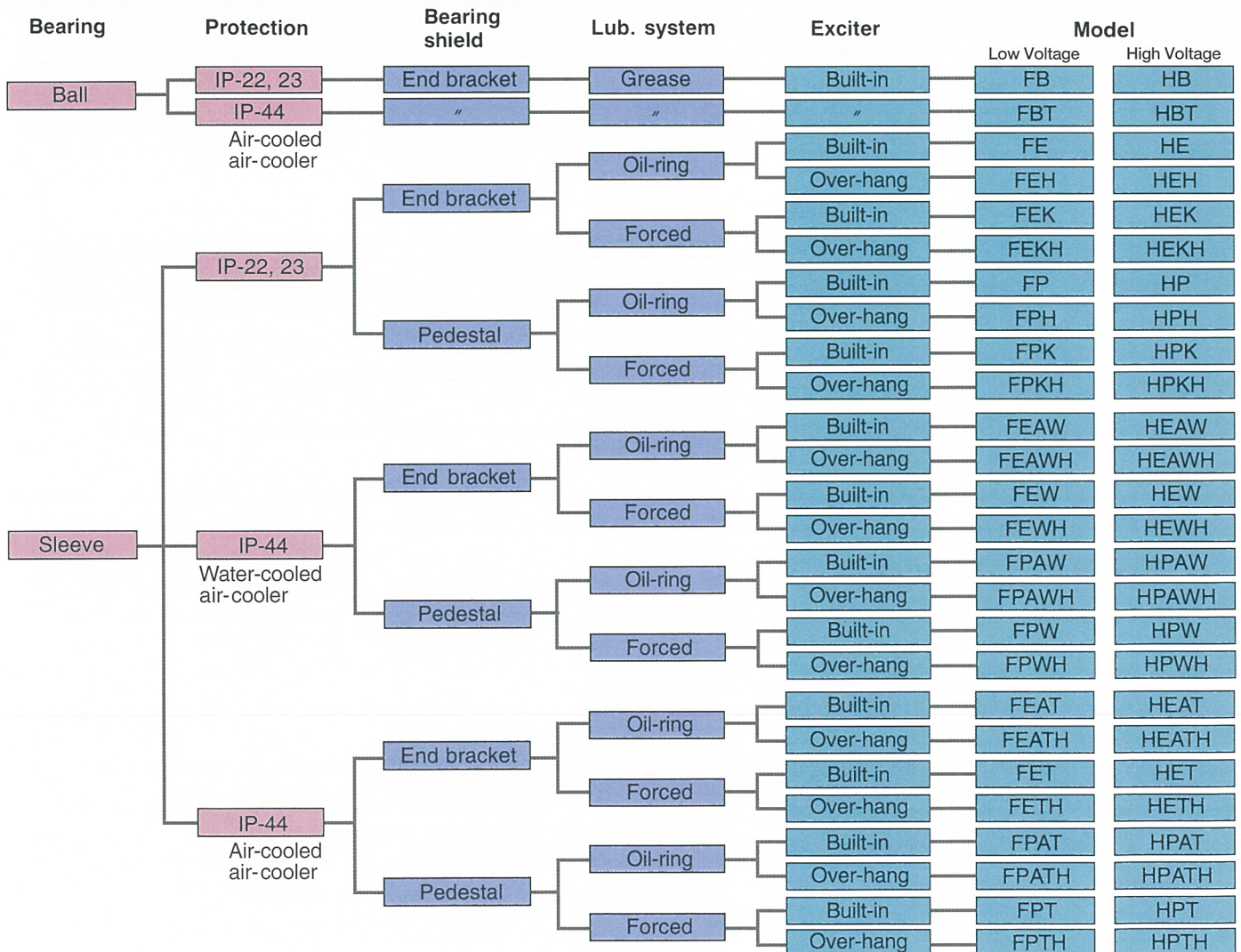

MAJOR MODELS

Frame Number Application Table & Outline dimensions of the respective models and capacities can be seen in the separate each pamphlet.

* Symbols for types: IEC60034

Enclosed, drip-proof self-ventilation type

Protection: IP-22, 23 (option)

Model FB, HB



Two endshield ball bearings type (IM1001 or IM1101)
10 kVA 1800 min⁻¹ — 650 kVA 1800 min⁻¹ or 525 kVA
1200 min⁻¹

Model FE, HE



Two or one endshield sleeve bearing(s) type, (IM1105
or IM1305) Oil ring type self lubrication
100 kVA 1800 min⁻¹ — 1500 kVA 720 min⁻¹ or 1125 kVA
600 min⁻¹

Model FEK, HEK

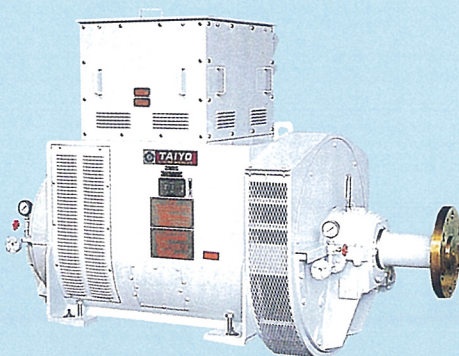

Two or one endshield sleeve bearing(s) type, (IM1105
or IM1305) Forced lubrication
450 kVA 1800 min⁻¹ — 2500 kVA 720 min⁻¹ or 2250 kVA
600 min⁻¹

Model FPK, HPK

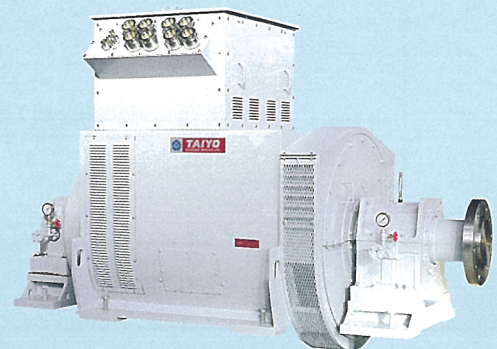

Two or one pedestal sleeve bearing(s) type, (IM7305
or IM7105) Forced lubrication
1125 kVA 600 min⁻¹ — 4000 kVA 600 min⁻¹

Totally-enclosed type, with water-cooled air cooler

Protection: IP-44

Model FEW, HEW

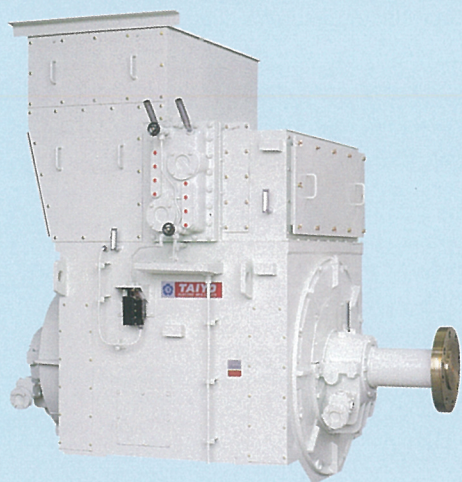

Two or one endshield sleeve bearing(s) type, (IM1105 or IM1305) Forced lubrication, with water-cooled air cooler
450 kVA 900 min⁻¹ — 2500 kVA 600 min⁻¹

Model FPW, HPW

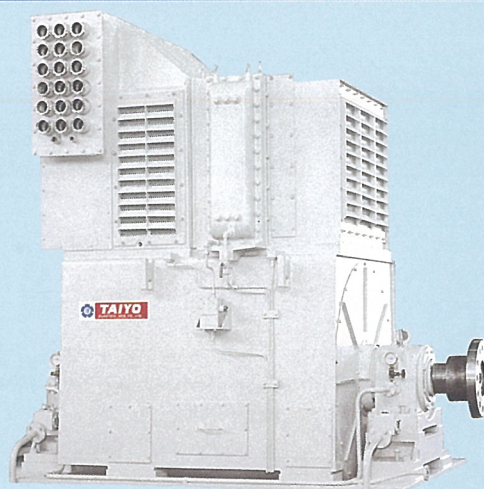

Two or one pedestal sleeve bearing(s) type, (IM7305 or IM7105) Forced lubrication, with water-cooled air cooler
1125 kVA 600 min⁻¹ — 4000 kVA 600 min⁻¹

Model FEWH, HEWH

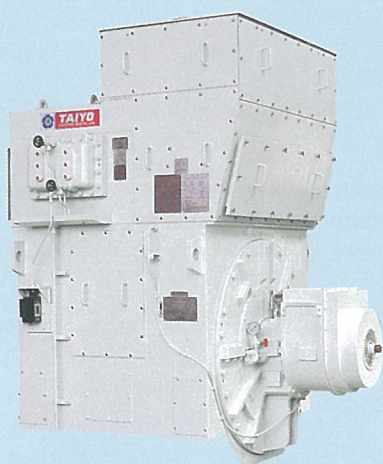

Two endshield sleeve bearings type, Forced lubrication (IM1101) with water-cooled air cooler, Over-hanged type rotating exciter
400 kVA 3600 min⁻¹ — 1875 kVA 3600 min⁻¹

Model FPWH, HPWH

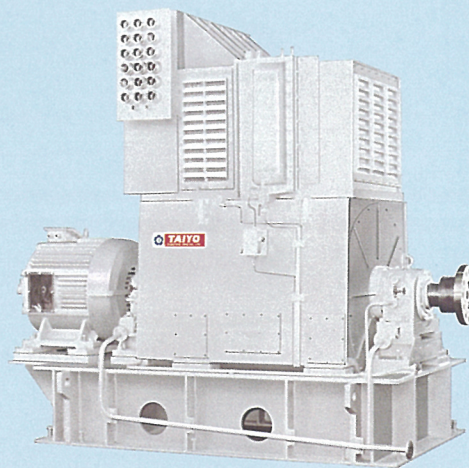

Two or one pedestal sleeve bearing(s) type, Forced lubrication, (IM7305 or IM7105) with water-cooled air cooler, Over-hanged type rotating exciter
1500 kVA 1800 min⁻¹ — 4000 kVA 1200 min⁻¹

FEATURES

HIGH RELIABILITY & LONG LIFE

As insulation and composition materials are carefully selected with the consideration of using condition and most up-to-date production technology is employed for manufacturing, high reliability and long life are ensured.

EASY HANDLING & MAINTENANCE

Brushless excitation system is employed, and structure of bearing part and winding part are designed for easy maintenance and inspection.

LIGHT WEIGHT & COMPACT

The use of F class insulation and cylindrical pole type having high cooling efficiency lead to light weight & compact. The accessories to be installed in the switchboard such as Automatic voltage regulator, Current transformer for cross-current compensation, Resistor for cross-current compensation and etc. are also made as quite compact size.

EXCELLENT ELECTRIC CHARACTERISTICS

Positive introduction of new technology, employment of high quality insulation materials and rational design produce excellent electric characteristics.

CONSTRUCTION

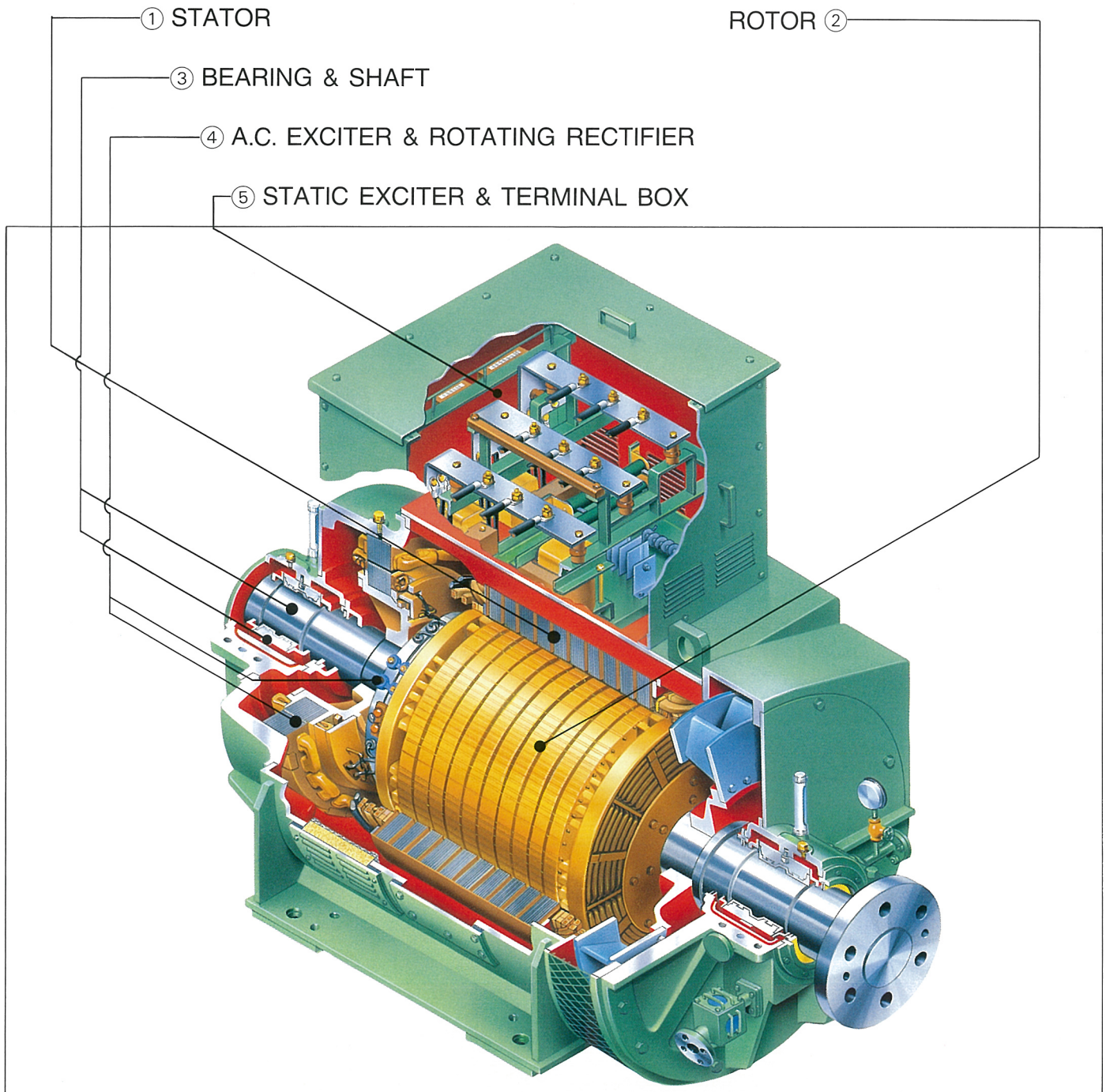

① **STATOR**

The stator frame is constructed of welded mild steel plates, being so designed as to have sufficient mechanical strength and to withstand electric shock.

The stator core is built in such a manner that silicon steel plate which is good in magnetic characteristics and coated with an insulating varnish for prevention of eddy current is punched, and the punched plate elements are piled along the inner circumference of the stator frame from one side and equipped with air duct at each of regular pile intervals. This construction reduces the iron loss of the stator and improves generator's efficiency.

The stator winding is formed of electric enameled wire of insulation class "F" polyamideimide, and slots of the stator core are protected with an insulating material of class "F".

The winding thus placed is fastened to the stator core by special wedges, while the coil ends outside the laminated stator cores have taping rendered, and then class "F" alkyd varnish are impregnated and dried to ensure characteristics

such as heat resistance, moisture-proof, salt-proof and oil-proof. With high-voltage generators, windings employ a high-performance insulated mica wire which is coiled and taped, then impregnated with VPI(Vacuum Pressurized Impregnation) system.

TAIYO "F" SERIES GENERATORS are therefore usable in excellent condition over a long period of time under particular marine environment.

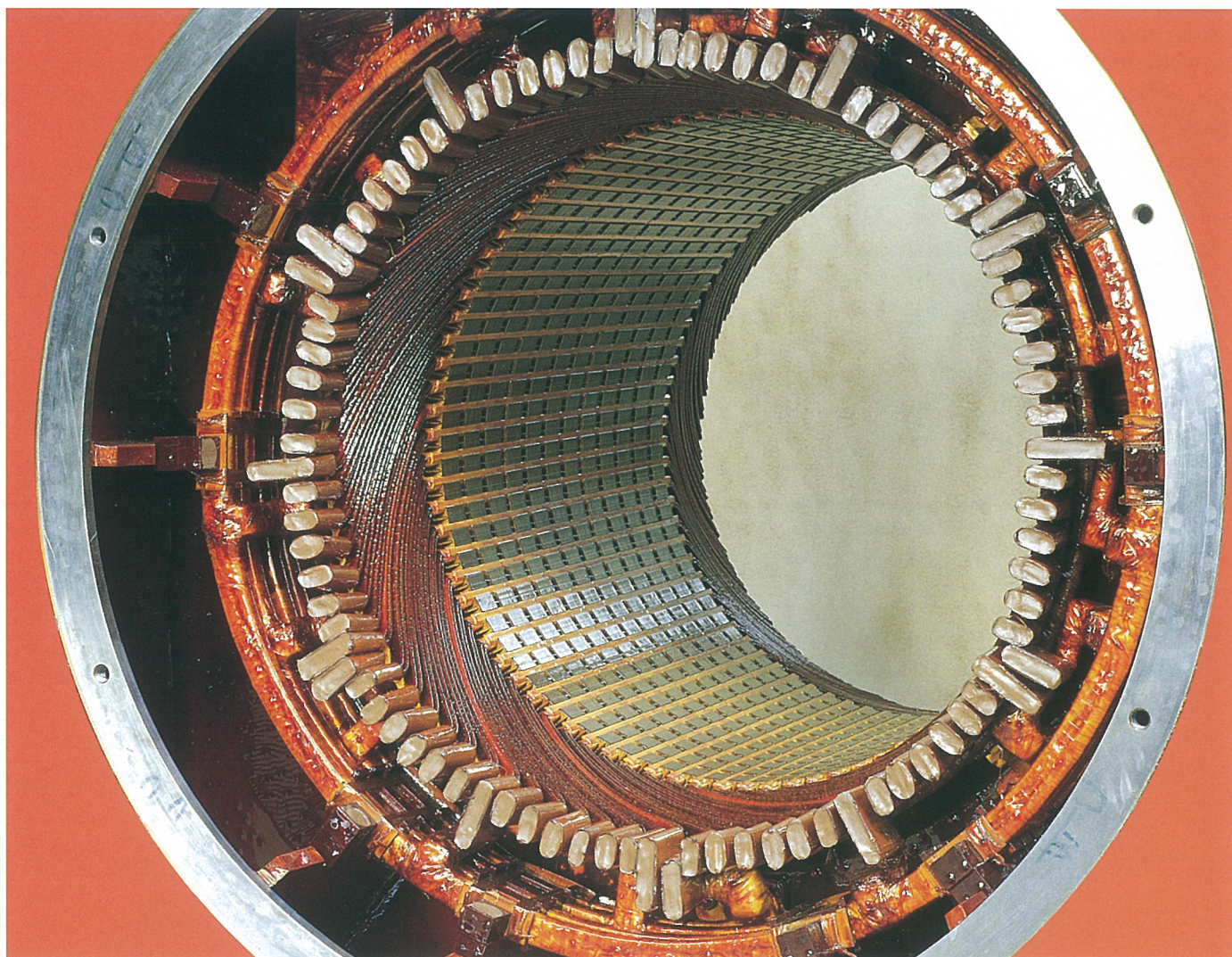

② ROTOR

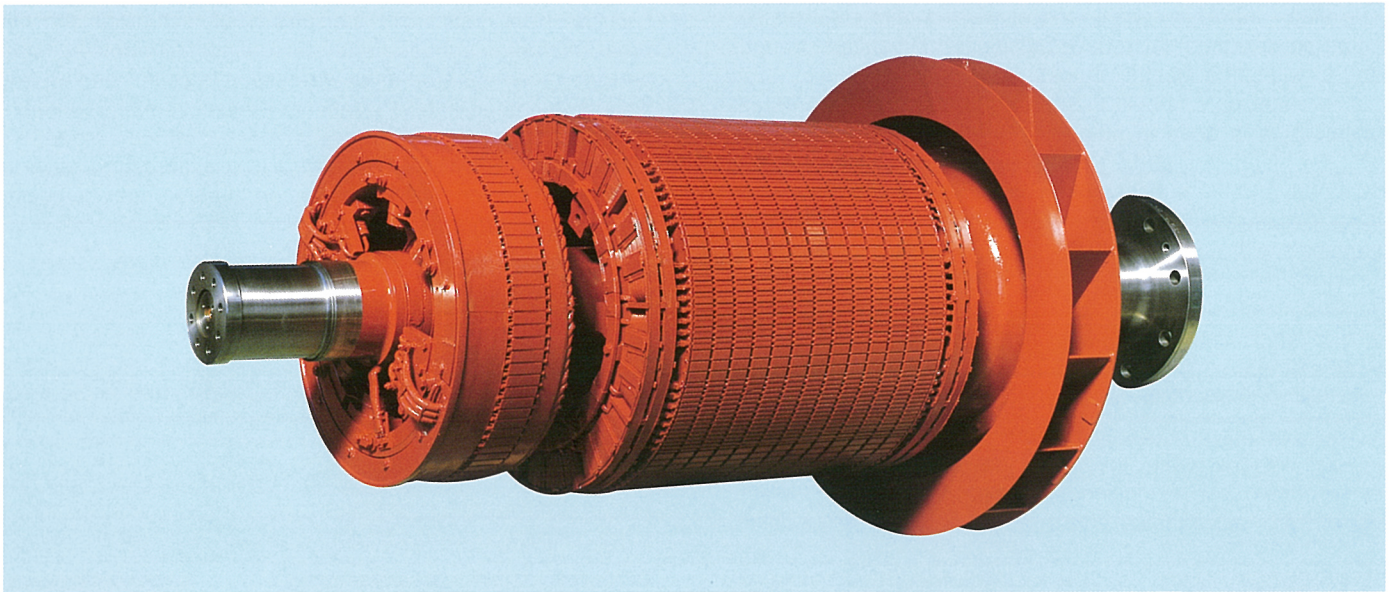

The field core is of a laminated construction. It is fitted into the shaft or spider and fixed at its ends by means of rotor clampers. This arrangement provides secure rotor installation and also protects the winding.

Field core are available in two different shapes, and the selection between them depends on their capacity and speed:

Salient pole type: Used on small capacity, high-speed generators; and small and medium capacity, low-speed generators.

Cylindrical pole type: Used on medium and large capacity, high-speed generators; and large capacity, low-speed generators.

The manner in which the field coil is wound differs according to the shape of its mating core. In either case, the coil is varnished properly to resist electric and mechanical stress:

Salient pole type: Concentrated winding

Cylindrical pole type: Distributed winding

MECHANICALLY STABLE STRUCTURE: Being integral in construction, both the salient pole and cylindrical cores are strong enough to withstand the stresses of the centrifugal forces.

EFFICIENT COOLING AND VENT. SYSTEM: It has vent holes provided in the axial direction of the magnetic core and also air ducts similar to those of the stator core in the longitudinal direction of the core so that it is enabled to cool the whole rotor with a sufficient amount of cooling air. Consequently the generators can be built in smaller size and lighter weight.

GREATER EFFECT OF DAMPER WINDING: The damper winding is distributed evenly over the whole periphery of the rotor so that the damper effect is great enough to permit stable parallel run of generators. Further, against the unbalance or thyristor load, a sufficient damper effect is obtainable.

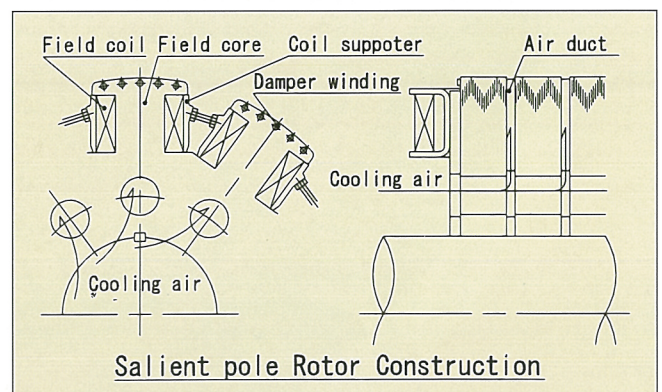
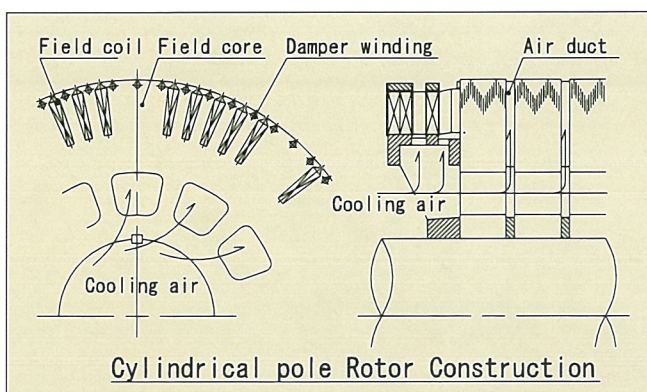

③ BEARING & SHAFT

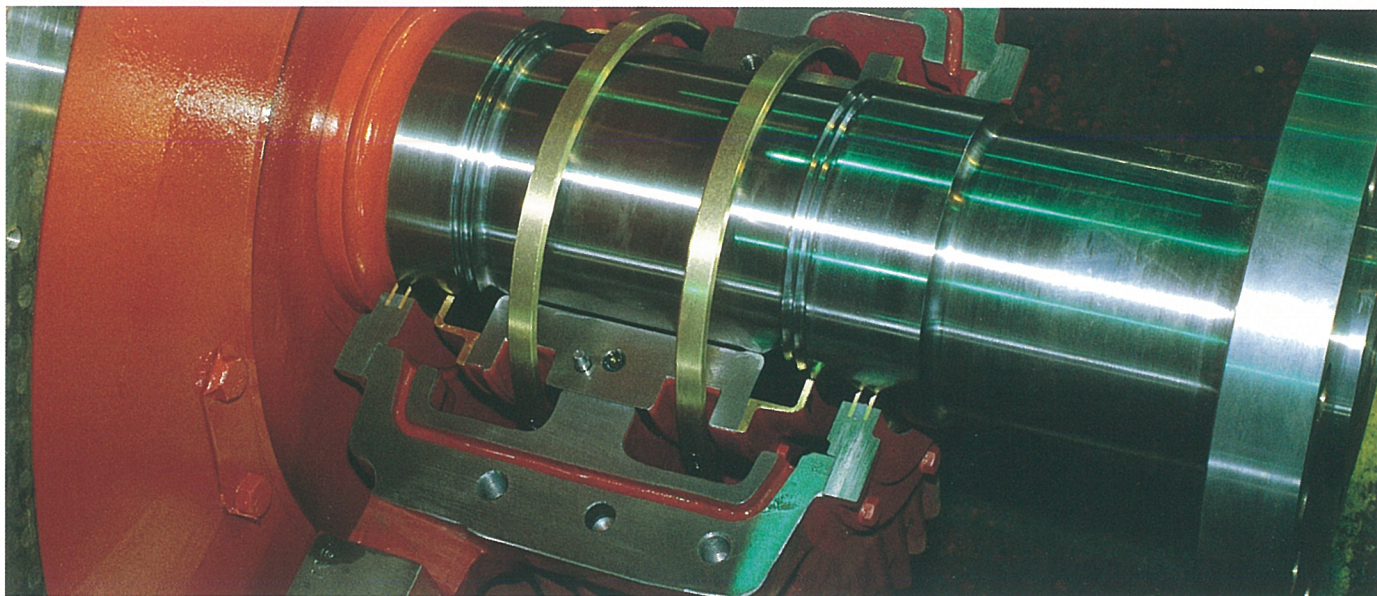

As a standard, ball bearings are used for small or middle size, and sleeve bearings are used for middle or large size. In lubrication system for sleeve bearing, self oil ring lubrication is normally used for middle or small and medium or low speed machine, and forced lubrication system is used for large and high speed machine.

These applications are decided by the consideration of capacity, revolution speed, coupling method and etc. (Refer to Model Application and each separate pamphlet of respective models). The sleeve bearings are each split in two for convenience of maintenance, and high quality white metal is firmly casted into inner surface. The bearing, case, end bracket or pedestal have sufficient strength to withstand external forces, axial load, and vibration.

Following lubrication oil is recommended as standard.

Ball bearing: Lithium type grease

Oil ring lub.: ISO VG46

Forced lub. for diesel generator (of 6 or more poles):
SAE No. 30

Forced lub. for turbo generator (of 4 or more poles):
ISO VG68

High quality forged steel is used for the shaft, and detail dimensions are carefully designed and manufactured after thorough discussion with prime mover maker about torsional vibration analysis.

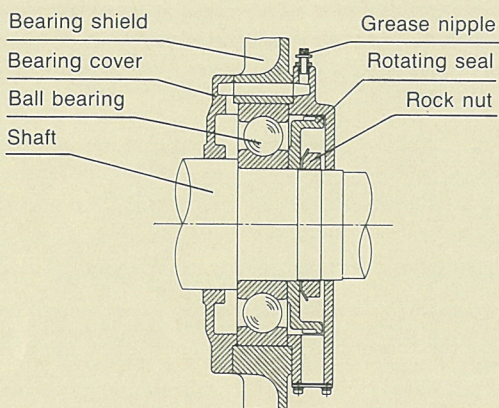

Model: FB
Bearing Construction

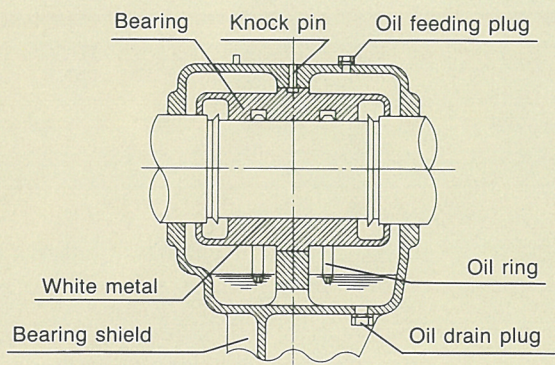

Model: FE
Bearing Construction

④ AC EXCITER

The AC exciter is a rotating-armature type exciter assembled, together with a rotating rectifier, onto the anti-coupling side of generator. The rotating rectifier is composed of a silicon rectifier (Si) and a discharging resistor (RC) for surge absorption.

3-phase full wave rectifier circuit is used as rotating rectifier, which has sufficient electrical strength and can ensure the large surge voltage. There are two methods of installing the silicon rectifier: Installation on the rotating rectifier's boss that is attached to two conductive discs or rings which has superior heat dissipation; and installation of the rectifier as a modular unit through a radiation fin.

The mechanical strength against centrifugal force and torque change is also thoroughly considered at the structure and installation method.

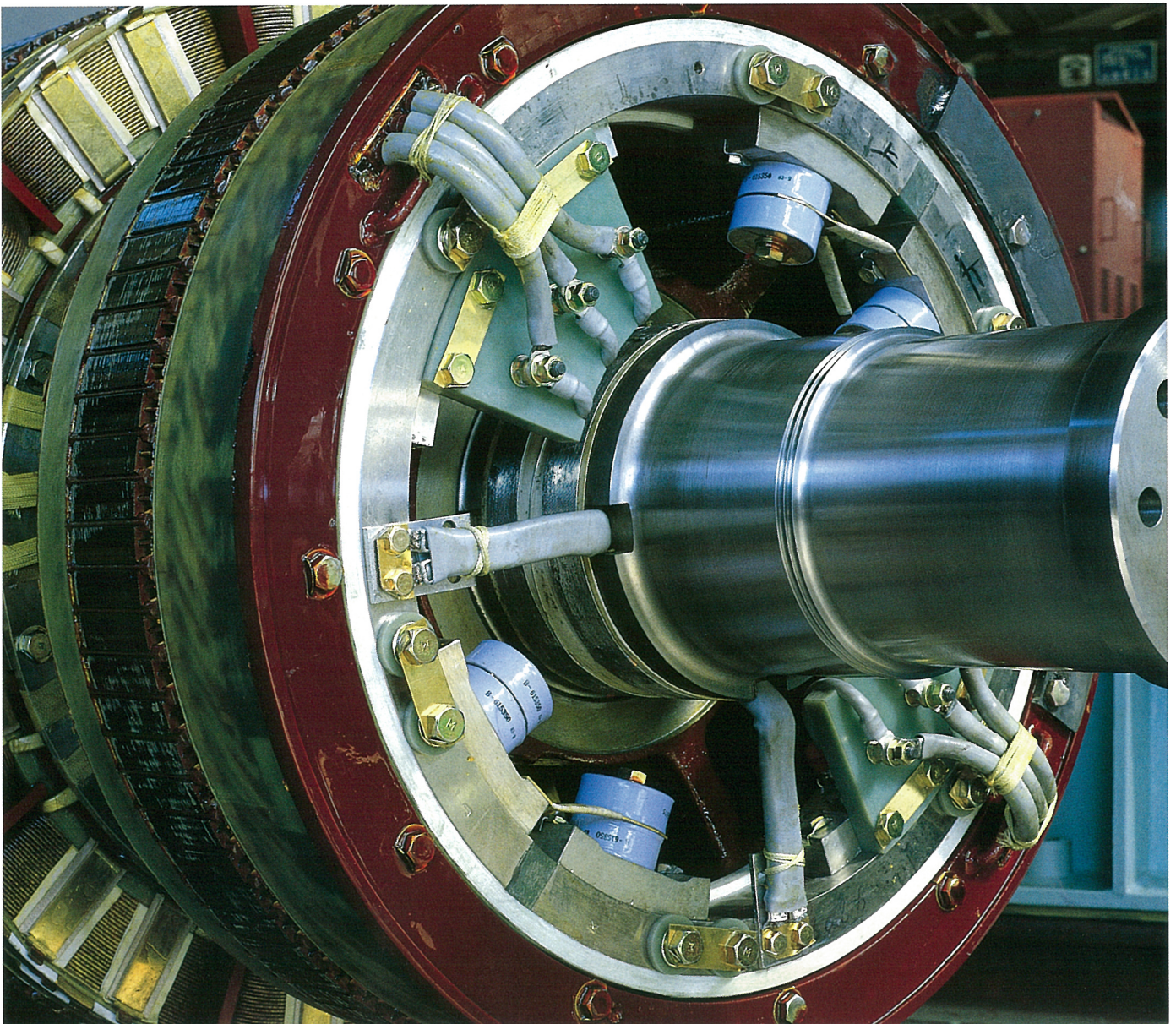

⑤ STATIC EXCITER & TERMINAL BOX

The static exciting system is composed of a Reactor (RT), Current transformer (CT), Silicon rectifier (Si), Automatic voltage regulator (AVR) etc. Normally, AVR, Voltage control rheostat (VR), and Current transformer for cross-current compensation (CCT) required for parallel operation are installed in the switch-board, while the other parts are placed in a box of drip-proof construction mounted on the top of the generator, and this box is also utilized as terminal box with containing bus bar terminals.

The marine cable glands are provided in any requested direction.

To obtain compound characteristics, TAIYO "F" series generator is in use of shunt control system, in which current proportioned to generator terminal voltage taken from a part of generator output through RT and current proportioned to load current taken from CT are composed in vector and this composed current is rectified to D.C. by silicon rectifier, then excites the field of A.C. exciter. Amature current of A.C. exciter generated by this excitation is rectified to D.C. by rotating rectifier fitted to the same shaft and excites the field of generator.

In this system, RT and CT are set to over compensation in advance as control amount, and this composed current is shunted by AVR to stabilize terminal voltage of the generator constantly against various load changes. Besides single field winding system is used for the field of this A.C. exciter and therefore highly responsive for a sudden large change in generator load, and is capable of generating a short circuit current of sufficient magnitude and duration of more than 300% for selective tripping.

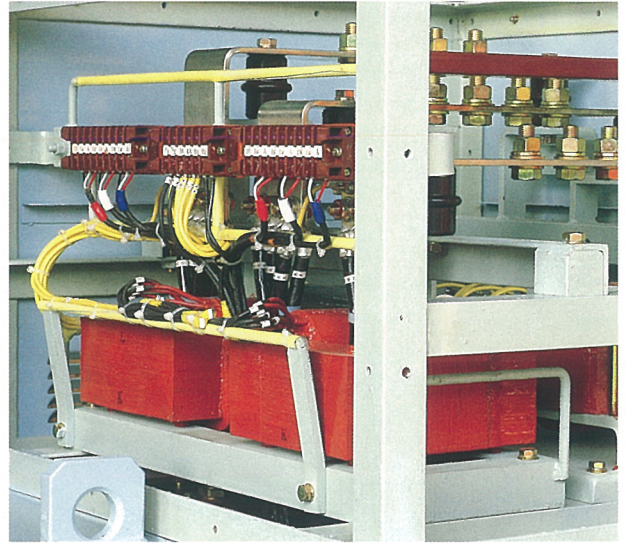

CONNECTION DIAGRAM

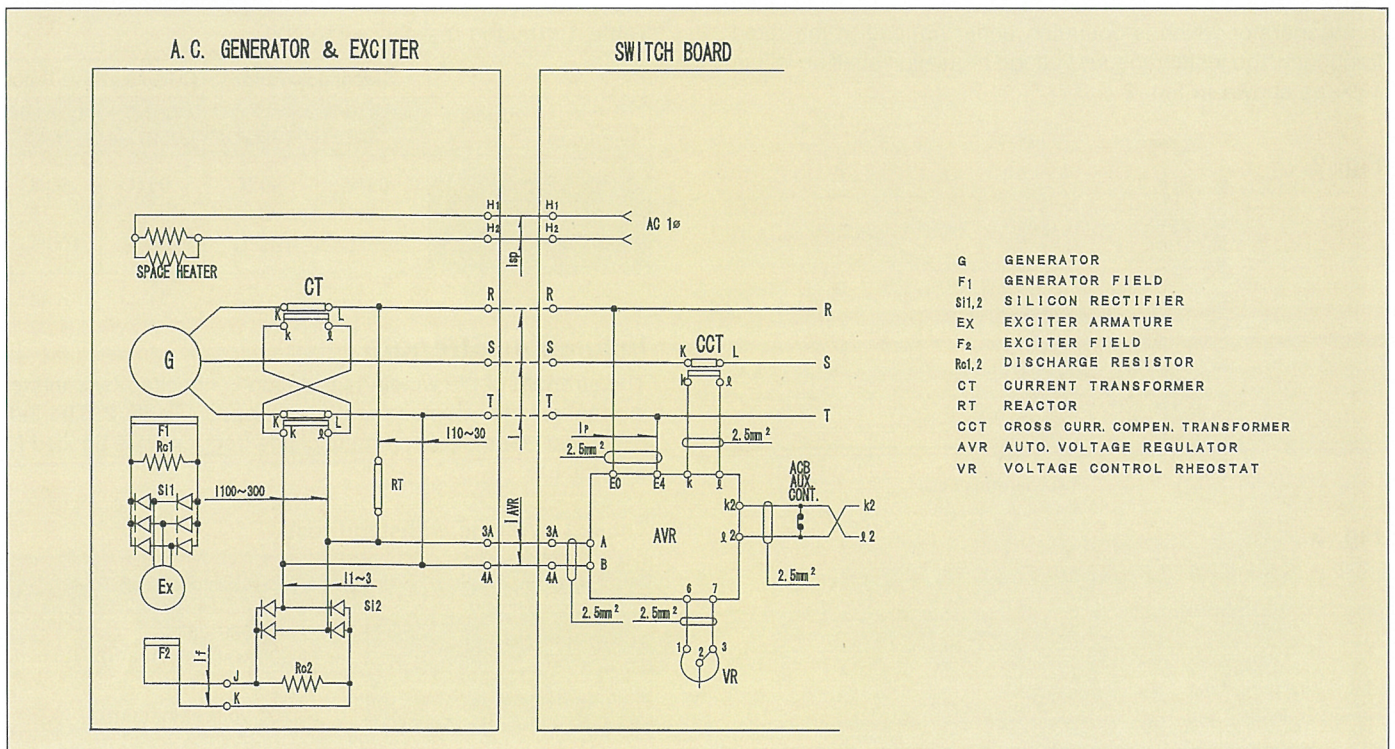

- Notes: 1) The Voltage control rheostat is not to be installed on the surface of the switchboard but in it's inside.
 2) The Current transformer for cross-current compensation will be supplied only when parallel operation is intended.
 3) Voltage fluctuation is almost none during parallel operation as Differential current transformer (DCT) is built in AVR.

Steady-state Voltage Regulation

Operating with its automatic voltage regulator, the generator gives its output voltage according to the regulation curve shown in Fig. 1.

- A. When the load on a generator is varied gradually from no load to full load or vice versa at the rated power factor, the variation of the steady-state voltage shall be within $\pm 0.5\%$ of the rated voltage.
- B. When the load on a generator is varied gradually from no load to full load or vice versa while the power factor is changed between 0.7 and 1.0, the variation of the steady-state voltage shall be within $\pm 1.0\%$ of the rated voltage.

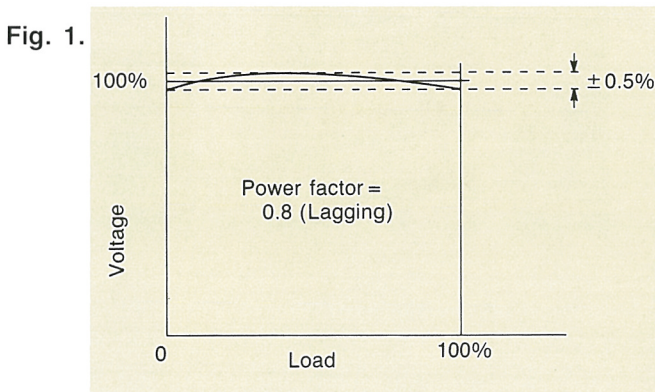

Instantaneous Voltage Regulation

When a load (125% impedance) corresponding to 80% (power factor below 0.4) of the rated current is suddenly given to a generator which is operating under no load at the rated frequency, the instantaneous voltage regulation shall be within 15% as shown in Fig. 2 & 3.

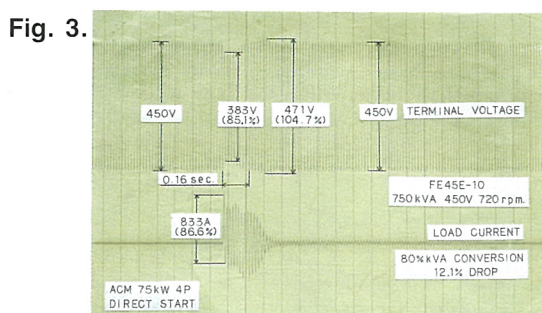
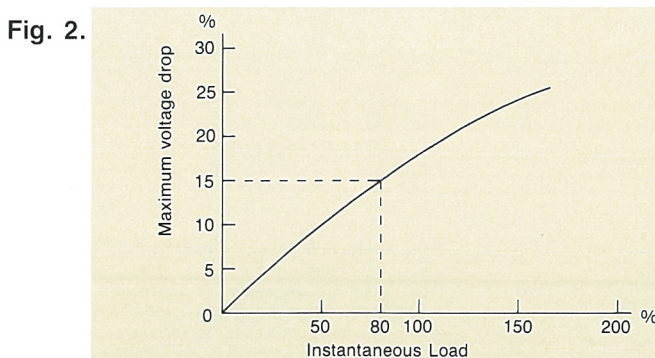

Exciter Resisting Property

When 150% (lagging power factor of 0.6) of the rated current is passed for 2 minutes in the condition in which the generator concerned is at the rated output with the temperature stabilized, the generator voltage can be retained at a value which proves no hindrance.

Voltage Wave Form

The wave form distortion of phase to phase voltage, as checked at the generator terminals, is not greater than 5% at no-load rated voltage.

Voltage Built-up

Since a special sort of steel plate which allows a relatively high voltage to remain is employed as rotor core material, the residual voltage is at least 25 volts. Voltage self-establishment is ensured even after long non-operation condition and therefore any pre-exciting device for voltage build up shall not be required.

Temperature Rise Limits

The temperature rise in the generator windings of class F insulation generator, as measured by the resistance method, is generally limited to the values indicated in Table 1 as standard, however the details of each part shall be in accordance with the requirement of applied classification societies.

Table 1. (by the resistance method)

Coolant	Salient pole Rotor		Cylindrical pole Rotor	
	45°C Air	50°C Air	45°C Air	50°C Air
Windings				
Stator winding	95°C	90°C	95°C	90°C
Field winding	100°C	95°C	105°C	100°C

Insulation Strength

The strength of the winding insulation is checked by conducting the voltage withstand test, described in Table 2. The indicated test voltage (of commercial line frequency) is applied for one minute.

Table 2. Voltage withstand test

Component	Test voltage
Stator winding	2E + 1,000 volts (1,500 volts minimum)
Field winding	10Ex (1,500 volts minimum)

Test voltage is impressed between winding and ground
 E = generator's rated voltage
 Ex = rated voltage of the exciter.

STANDARD ACCESSORIES

Water-Cooled Air Cooler

(For water-cooled air cooling type generator only)

The totally enclosed IP-44 type generator requires water cooled air cooler (Cooling-Air to Cooling-Water) mounted on top of the generator and uses sea water or fresh water for cooling.

Cooling tube is double tube construction having the leak-detecting groove. This tube has the excellent resistance against the corrosion and erosion-corrosion, which leads to its long life. Number of cooling pipes required plus 20% are built in advance; these additional pipes shall be served for 15% of fouling ratio and 5% of spare.

A proper sacrificial anode material (zinc for sea water, mild steel for fresh water) is provided as protection metal against electrolytic corrosion, which can be easily replaced from outside without removing water chamber. In the event of a failure of the cooler, generator can be converted to drip-proof machine by adjusting the blind plate and can be operated continuously by 100% capability.

- Inner tube: Aluminum brass for sea water, Copper for fresh water
- Outer tube: Finned copper
- Water chamber: Cast iron with Neoplene coating
- Tube plate: Naval brass
- Leakage detector: Float type

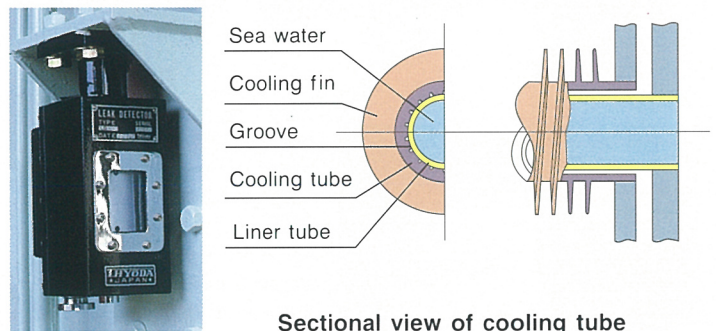
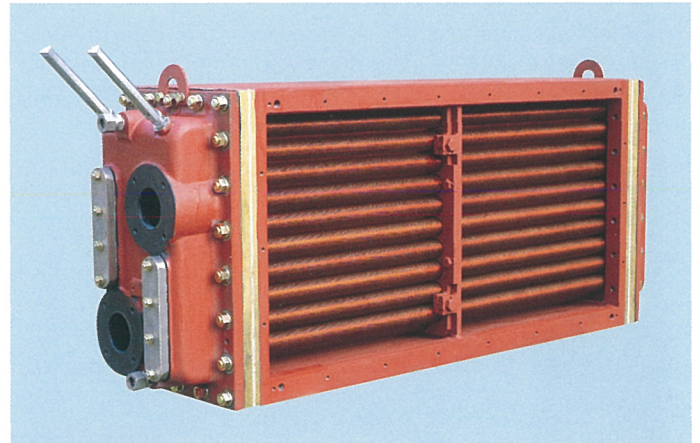

Leakage detector

Sectional view of cooling tube

Automatic Voltage Regulator & Voltage Control Rheostat

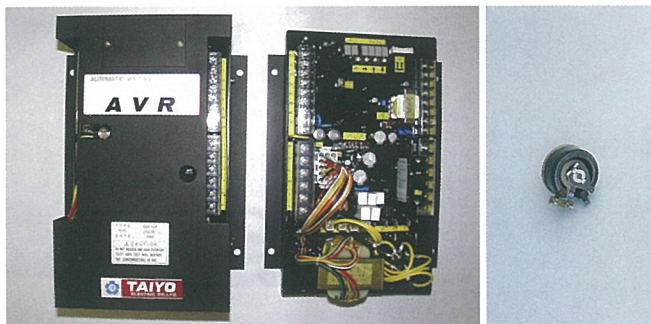

The EXU Type AVR adopts a microprocessor to offer supreme constant voltage characteristics, compact size, and reduced weight. By molding the printed circuit board, the EXU Type AVR is a highly durable voltage regulator even when used in severe environments subject to heavy vibration, high temperature, high humidity, etc.

TAIYO AVR does not require any specific noise-preventing filter as leakage reactance of a power transformer installed in it serves the function of the noise-filter.

Variable resistor is used for setting of the terminal voltage as voltage control rheostat. To be used together with AVR as pair, and normally installed in the switchboard.

Alcoholic Bar Type Bearing Thermometer

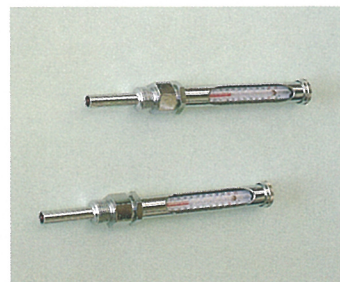

With centigrade scale. One for each sleeve bearing (Not to be provided for a ball bearing type)

STANDARD ACCESSORIES

OPTIONAL ACCESSORIES

Anti-condensation Heater

Sheathed wire type element is installed in the stator frame, and the circuit shall be interlocked with the aux. terminal of A.C.B. so that it will be activated automatically while the generator is not in use.

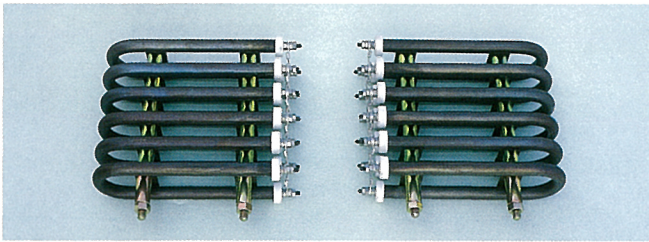

AC100, 110 or 200, 220 V single phase

Air Filter



Type: Bonden 292S
Material: Polyster
Heat Resistance: Up to 100°C (with flame retarding and self - fire - extinguishing properties.) Regeneration is possible by washing with water.

Current Transformer for Cross-Current Compensation

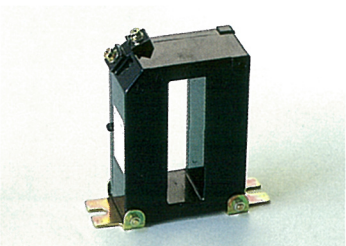

To be provided only when parallel operation is intended, and shall be installed in the switchboard.

Embedded Temperature Detector for Stator Winding

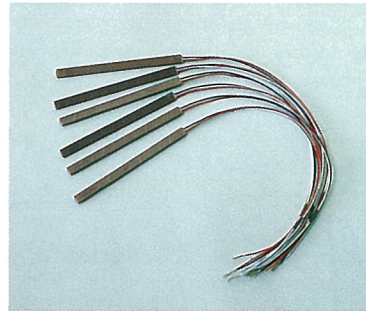

PT 100 ohm sensor.
6 pcs for each generator
(3 for working, 3 for spare)

Thermostat for Outlet Air Temperature of Air Cooler



Thermostat is provided to protect generator by sending alarm signal in case cooling water is not supplied rightly. (Normal closed contact).

Auto. De-excitation Device

Following parts are provided for each generator to protect generator against short-circuit accident from stator winding up to ACB.

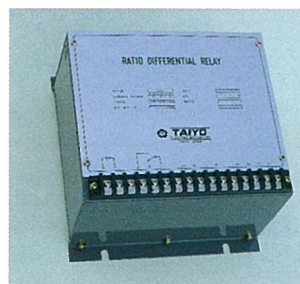

Ratio differential relay unit

1 set of Solidstate ratio differential relay (To be installed in the switchboard)
6 sets of Current transformer (3 sets at the neutral to be mounted on the generator and other 3 sets to be installed in the switchboard)
1 set of Relay for exciter field short circuiting (To be installed in the switchboard).

Some of the optional accessories may be provided as standard by the requirement of applied classification society.

STANDARD SPARE PARTS

Thermister & Relay Unit for Stator Winding

- PTC thermistor sensor 6 pcs for each generator (3 for working, 3 for spare)
- Electronic type relay unit one pc. for each generator

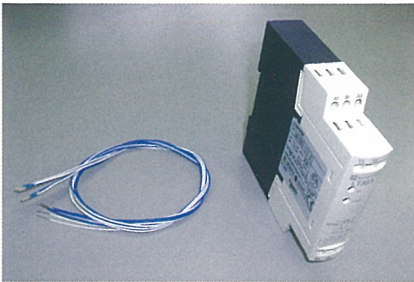

Embedded Temperature Detector for Bearings

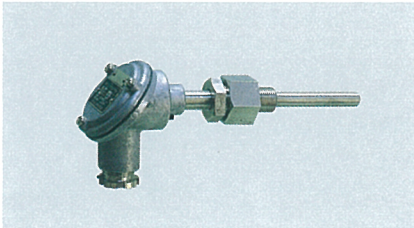

PT 100 ohm sensor
One set for each bearing

- **Bearing** One set for each kind of every 4 working sets or less
- **Resistor** One set for each kind of every 10 working sets or less
- **Air filter** Working quantity
- Others required by applied classification society are also provided as standard.



TAIYO ELECTRIC CO., LTD.

Head Office

No. 16-8, 1-chome, Uchi-Kanda,
Chiyoda-ku, Tokyo 101-0047 Japan
Phone : +81 3 3293 3067
FAX : +81 3 3292 7012

Factories

Gifu, Gifu hashima, Kani, Isesaki, Gunma

Branches

Shimonoseki, Mihara, Sapporo

Overseas Office

Shanghai Liaison Office
RM 14D, No.55 Lane 800,
Zhongshan(w) Road, Shanghai, China
Phone : 86-21-62415961
FAX : 86-21-62346939

Pusan Liaison Office
1509-13, Dadae-Dong,
Saha-Gu, Pusan, Korea
Phone : 051-265-0255
FAX : 051-265-0250

Singapore Representative Office
8 Penjuru Lane BH Global Marine
Bldg. Singapore 609189
Phone : 65-6210-8082
FAX : 65-6261-1644
